

Telescopic Leader Rig ABI TM 13



Base Carrier	SR 20 F
Engine Type	Cummins B6.7
Engine Power	209 kW
Emissions Standard	EU Stage V
Operating Weight ¹	44.3 tonnes
Transport Weight ²	40.6 tonnes

¹Operating weight = base carrier + mast + attachment

²Transport weight = base carrier + leader mast

Telescopic Leader Mast	TM 13
Total Height	17590 mm
Maximum Pile Length	13 m
Feed Force mast cylinder 1 up/down (on guiding carriage)	180 kN / 100 kN
Feed Force mast cylinder 2 up/down (on guiding carriage)	180 kN / 100 kN
Torque Absorption Max.	60 kNm
Docking Rig	Yes
Bearing Pressure	269 kN/m ²

Auxiliary Winch	
Line Pull at Min. Reach	14 kN
Line Diameter	8 mm
Speed Adjusted	34 m/min

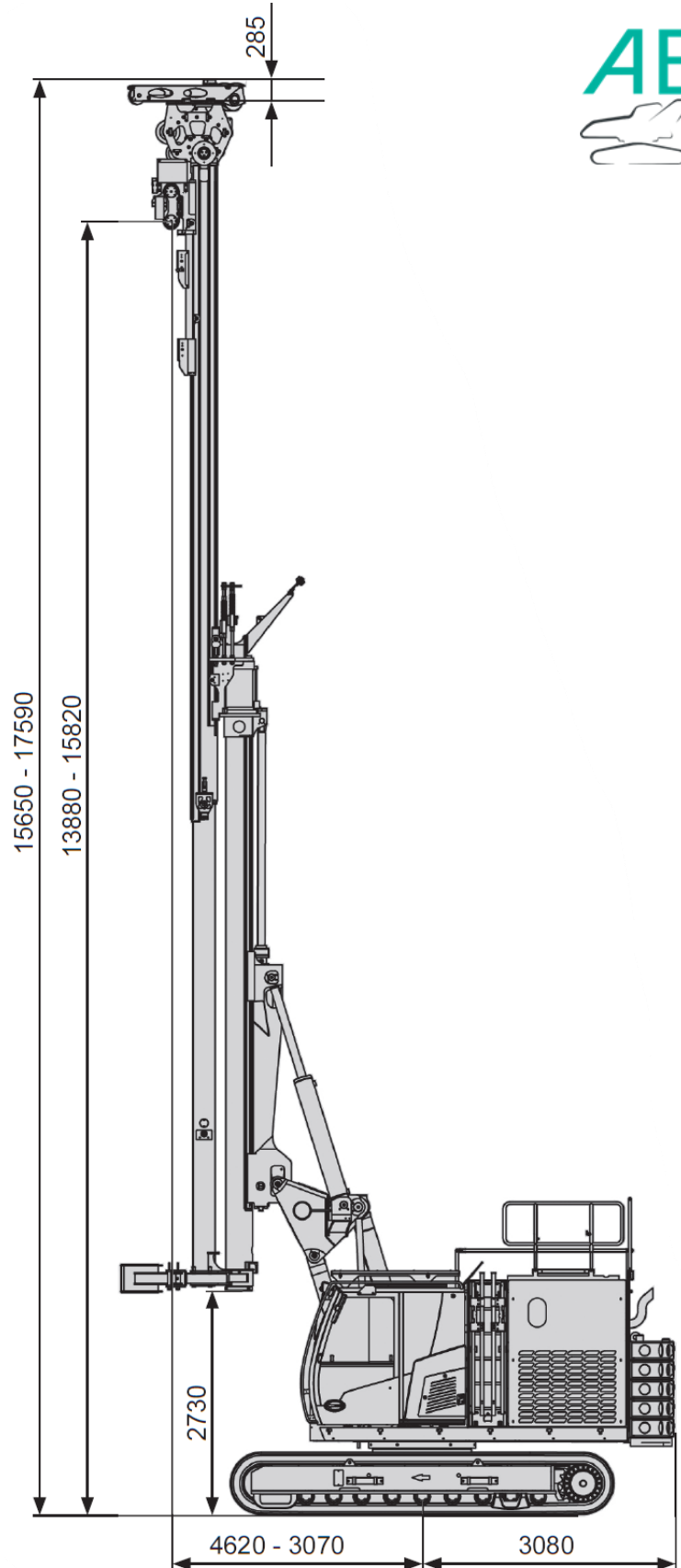

Telescopic Leader Rig ABI TM 13

Transport Weights & Dimensions ▼

Standard Counterweight (A) [detachable]	5 x 1500 kg
Base Plate for Counterweight (B) [detachable]	1400 kg
Winch (option)	150 kg

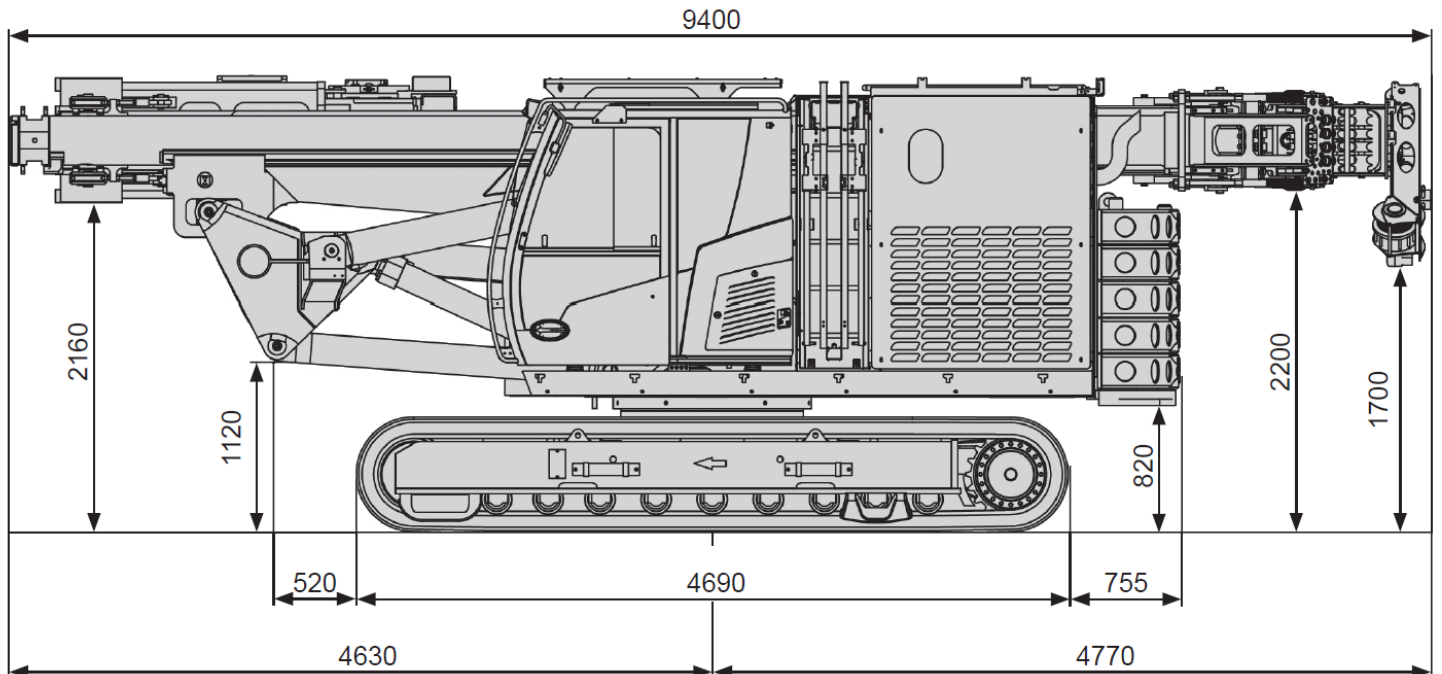
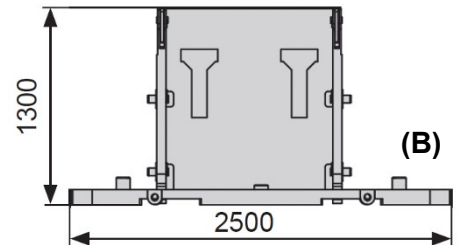
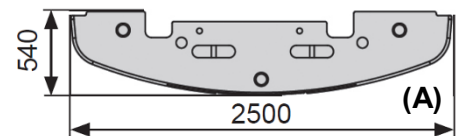
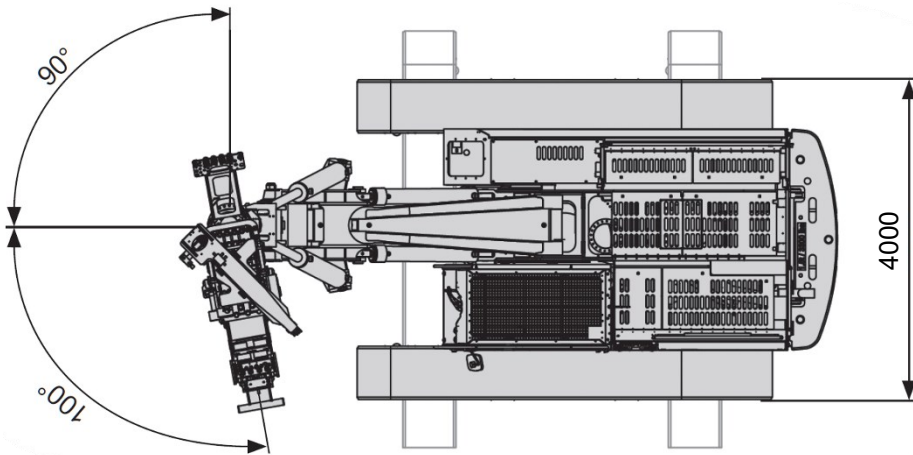
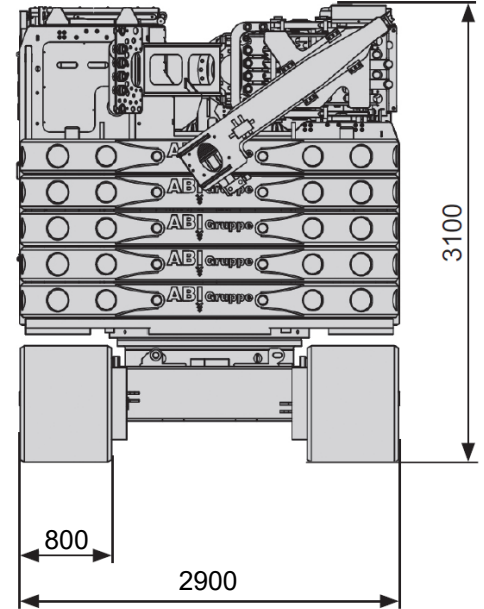
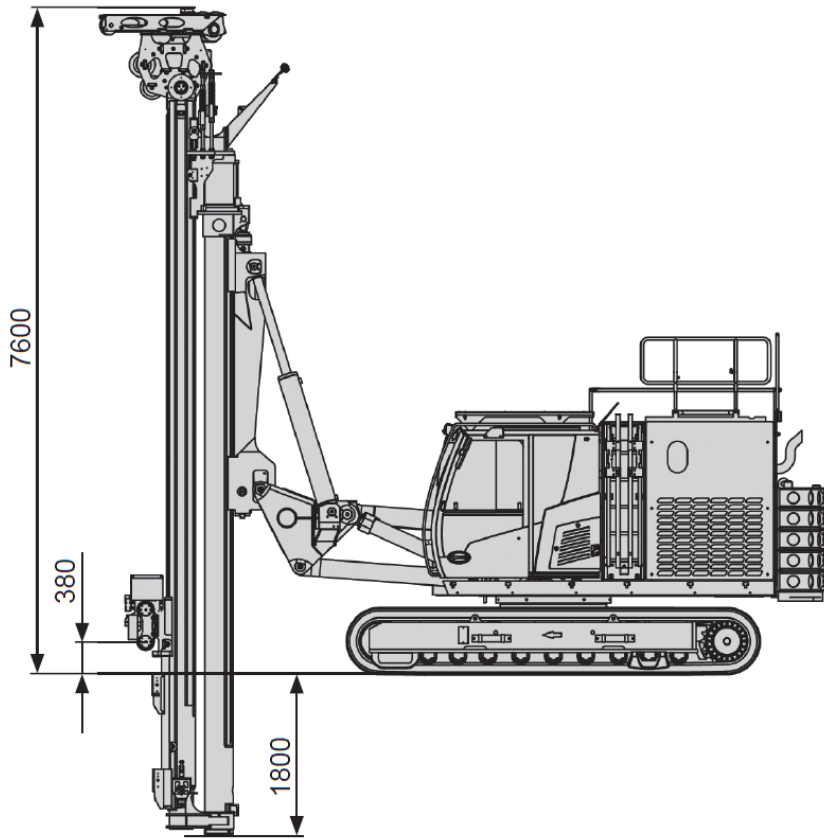

Telescopic Leader Rig ABI TM 13

Attachments

Vibration Hammer	MRZV 16VV
Height (H)	2920 mm
Width (W)	790 mm
Depth (D)	1280 mm
Guide to Driving Axle (R)	550 mm
Min Clearance to Centre Line of Pile (V)	730 mm
Static Moment	0 -16 kgm
Dynamic Mass	2360 kg
Maximum Revolutions	2600 / minute
Centrifugal Force at Nominal Frequency	600 kN
Maximum Centrifugal Force	600 kN
Total Weight	3640 kg
Transport Weight	3900 kg

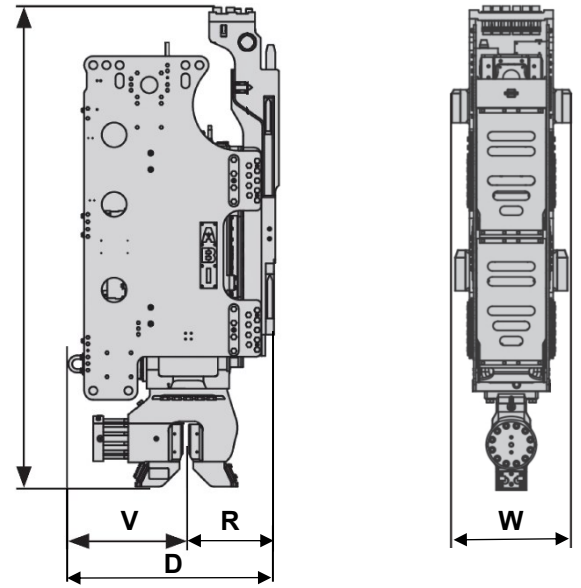

ABI Auger Drive	MDBA 7000-2	MDBA 7000-2*
Height (H1 / H2)	3120 mm / 2470 mm	
Width (B1 / B2)	835 mm / 1010 mm	
Depth (T)	925 mm	
R	600 mm	
S	2635 mm	
X	325 mm	
Torque	6600 daNm	3300 daNm
Maximum Revolutions	40/min ⁻¹	80/min ⁻¹
Static Extraction Force Maximum	300 kN	
Maximum Auger (diameter / length)	Ø 600 mm / 13 m	
Total Weight	1900 kg	
Transport Weight	2100 kg	



*Refers to MDBA 7000-2 Auger Drive hydraulic motor including two-speed valve

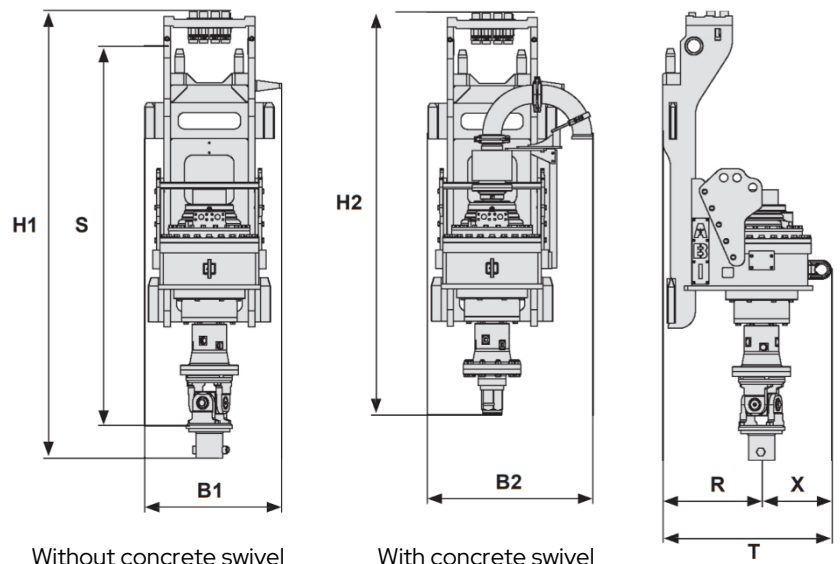

Telescopic Leader Rig ABI TM 13

Delmag Diesel Impact Hammer	D19 - 52
Length of hammer without extension A	5500 mm
Outer diameter of impact block B	440 mm
Width of hammer	485 mm
Impact weight (piston)	1820 kg
Energy per blow	66 - 29 kNm
Number of blows per min	33 - 52 / min
Suitable for driving piles	1100 - 6000 kg
Weight of hammer	4100 kg
Max. inclined pile driving without / with extension	1:5 / 1:1

NOTES

Installation is only allowed in combination with D6 slide adapter.

Kinematics have to be positioned at minimum reach and can be adjusted within a range of 100mm.

Cylinder II is fully useable while cylinder I is limited in its stroke.

Maximum useable length underneath Delmag D19-52 anvil of approximately 8m (less pile cap, etc.)

Diesel pile hammer is only allowed to be used for back driving work.

