

Giken Reaction Base (GRB) System

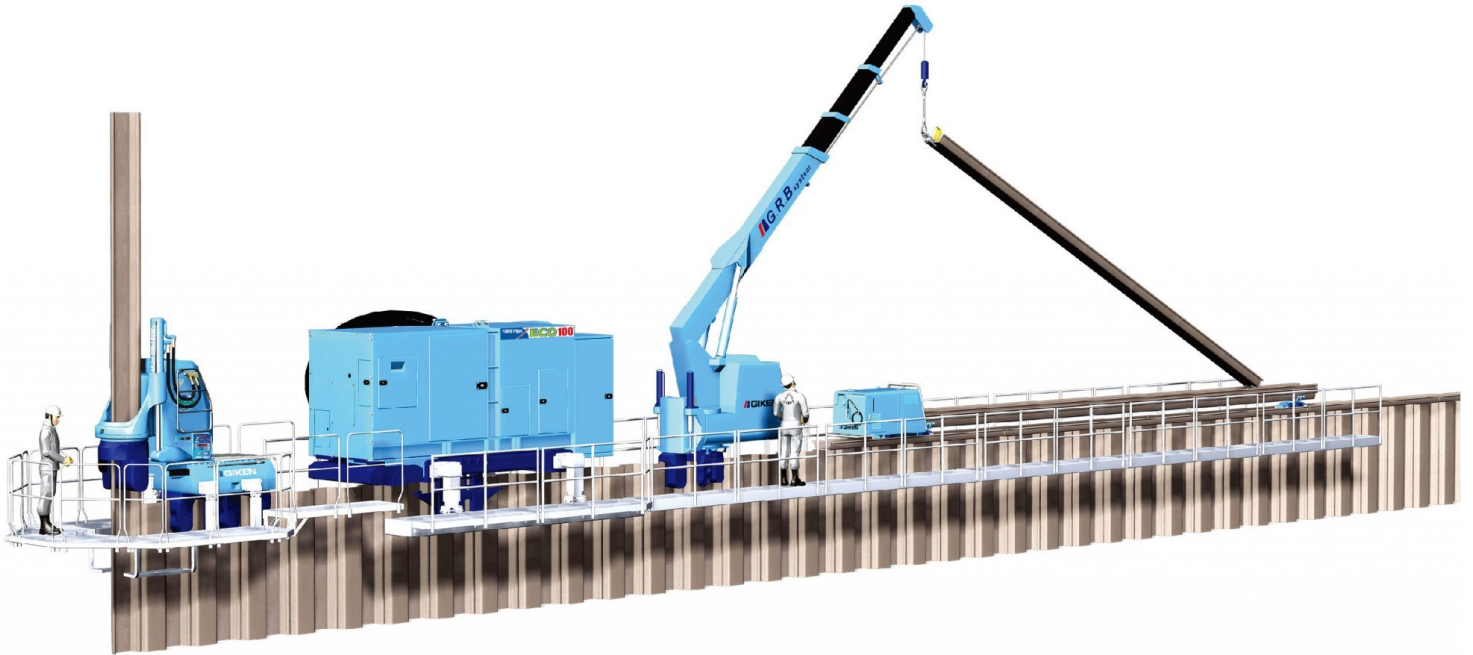

Giken CB3-4 Clamp Crane

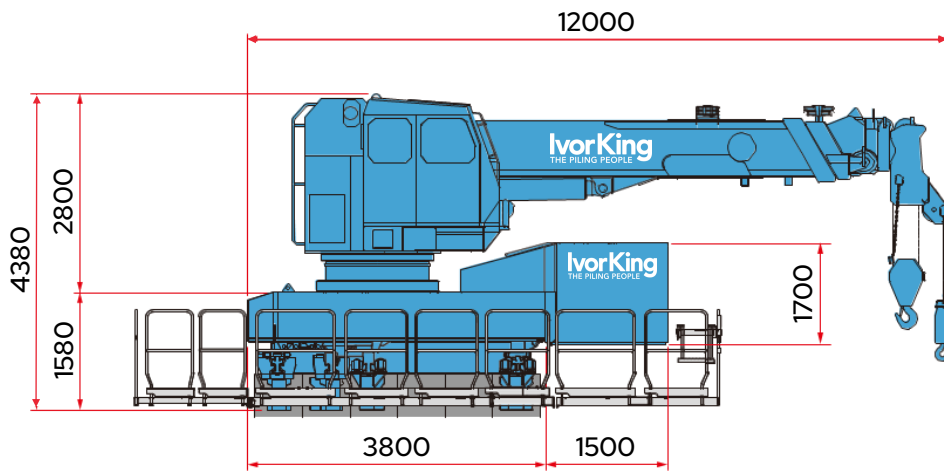

Technical Data

Lifting Capacity	10,000 kg @ 6.5 m
Max. Working Radius	30 m
Crane Operation	Manual

Technical Data - Weight

Power Unit	4,000 kg
Lower Assembly	8,000 kg
Crane Body	7,000 kg
Crane Boom	5,000 kg
Staging Sections (each)	135 kg
Clamp Crane (w/o staging)	24,000 kg

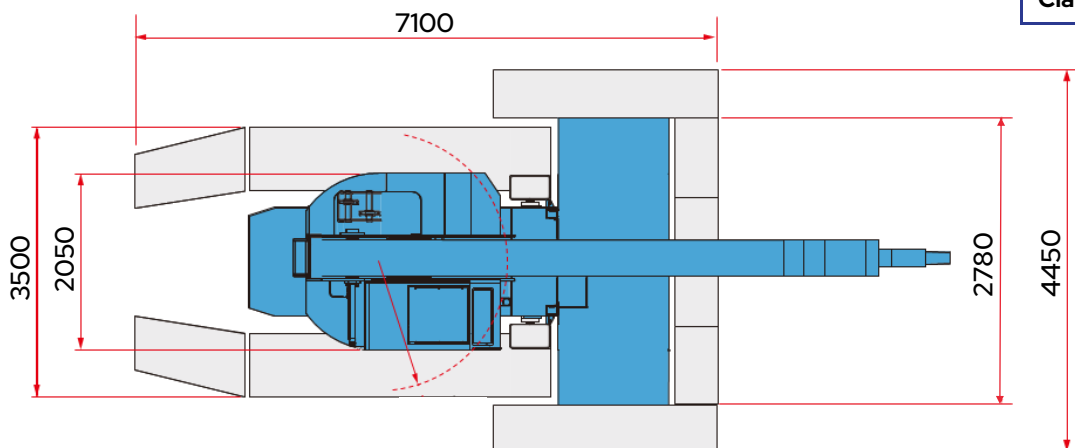

Giken Reaction Base (GRB) System

Unit Runner UR3 (for Giken Power Pack)

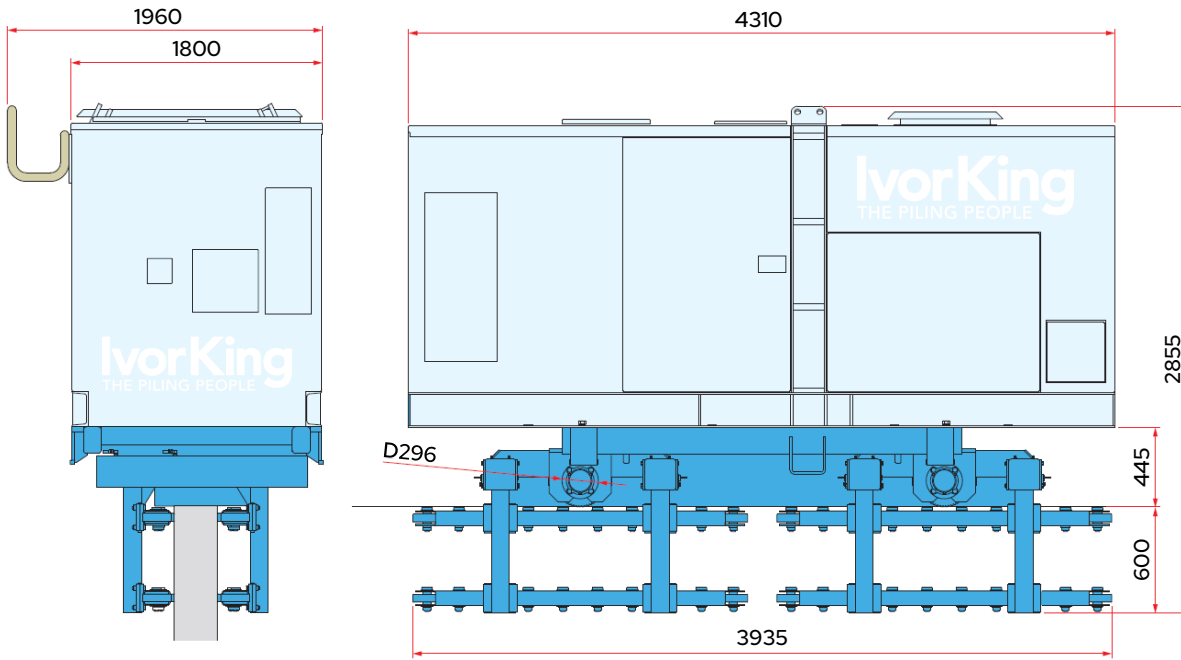

Technical Data UR3	
Power Unit	EU300K4
Travel speed	10 m/min
Movement on piles	Remote Control
Weight (excl. Power Pack)	2,350 kg

Dimensions when EU300K4 Power Pack is mounted on UR3 Unit Runner

Pile Runner PR4 (for transporting sheet piles)

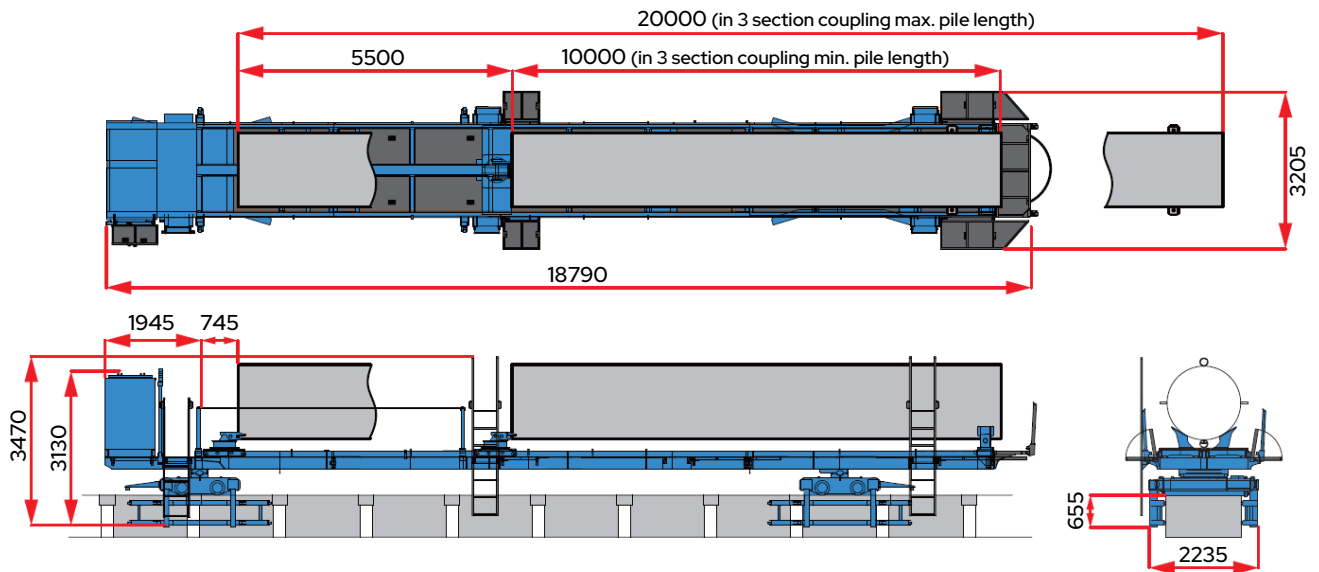

Technical Data PR4		
Maximum load capacity		10 tonnes
Pile length	in 3-section coupling	10 m to 20 m
	in 2-section coupling	8 m to 13 m
Travel speed	Normal	10 m/min
	Fast	15 m/min
Weight		13,500 kg