

Telescopic Leader Rig RTG RG21T



Base Carrier	BS 65 RS
Engine Type	CAT C18
Engine Power	570 kW
Operating Weight (approx.) ¹	85 - 89 tonnes
Transport Weight ²	76 tonnes

²Transport weight = base carrier + leader mast
¹Operating weight = base carrier + mast + attachment

Telescopic Leader Mast	RG21 T
Total Height	27584 mm
Mast Height Extended	23981 mm
Mast Height Retracted	14861 mm
Maximum Pile Length	21.4 m
Working Radius Min.	4307 mm
Working Radius Max.	6100 mm
Swing Radius	3860 mm
Extraction Force	260 kN
Crowd Force	140 kN
Torque absorption Max.	150 kNm

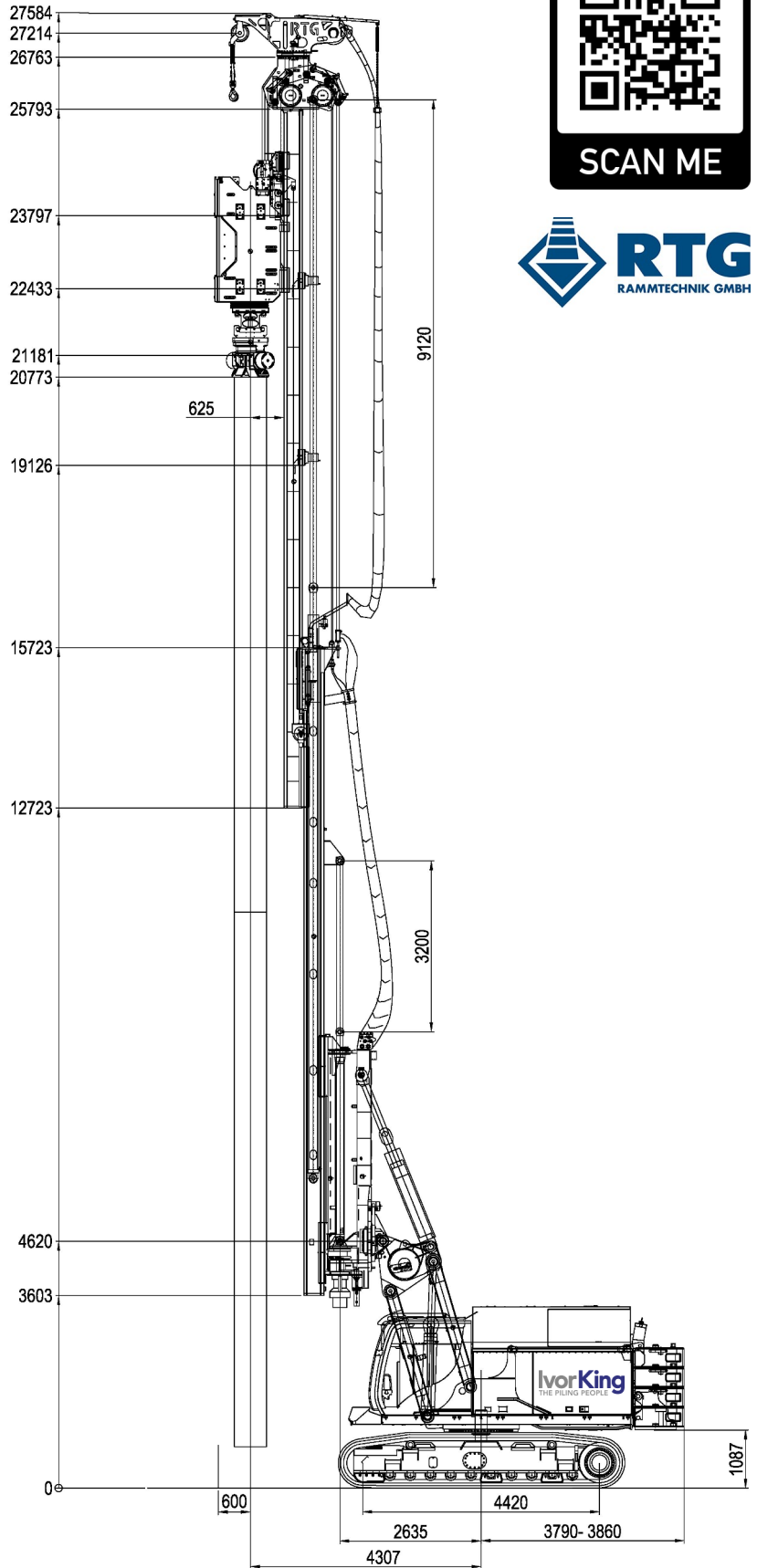

Telescopic Leader Rig RTG RG21T

RTG MR 150 AVM Hydraulic Vibrator

Technical Data	MR 150 AVM
Height (A)	3200 mm
Width (B)	530 mm
Depth (C)	1400 mm
Guide to Driving Axle (D)	670 mm
Min Clearance to Centre Line of Pile (E)	730 mm
Static Moment	0 – 28.4 kg-m
Hydraulic Power at Vibrator	480 kW
Maximum Revolutions	2500 / min
Maximum Centrifugal Force	1500 kN
Total Weight	5000 kg
Transport Weight	5350 kg

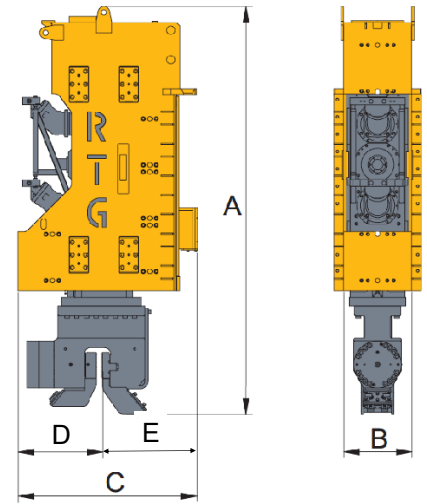

RTG MRZ 85 Clamp Assembly

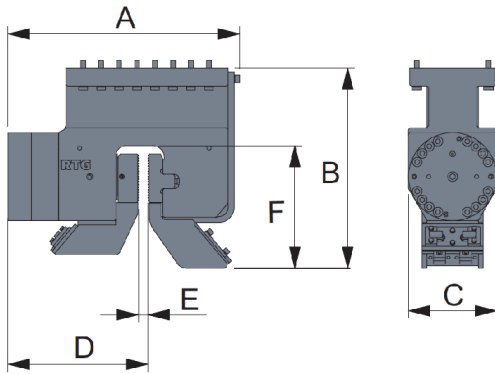

Technical Data	MRZ 85
Depth (A)	800 mm
Height (B)	655 mm
Width (C)	350 mm
Guide to Driving Axle (D)	551 mm
E	39 mm
F	443 mm
Maximum Centrifugal Force	850 kN
Total Weight	5000 kg

RTG T1 (for pairs of sheet piles)

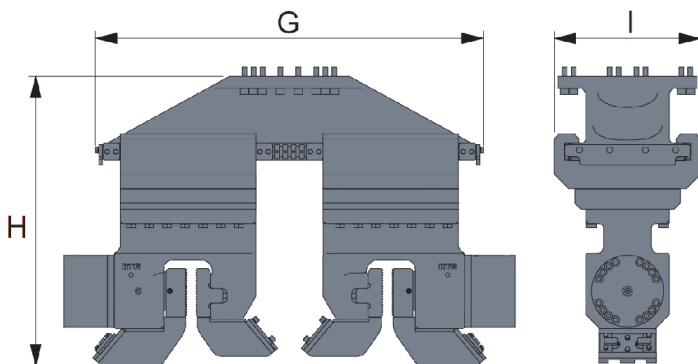

Technical Data	T1
2 Clamp assemblies	MRZ 85
Weight	1750 kg
Casing inner diameter	Min. 500 mm
	Max. 930 mm
G	1620 mm
H	1210 mm
I	610 mm



Telescopic Leader Rig RTG RG21T

RTG Sheet Pile Press System

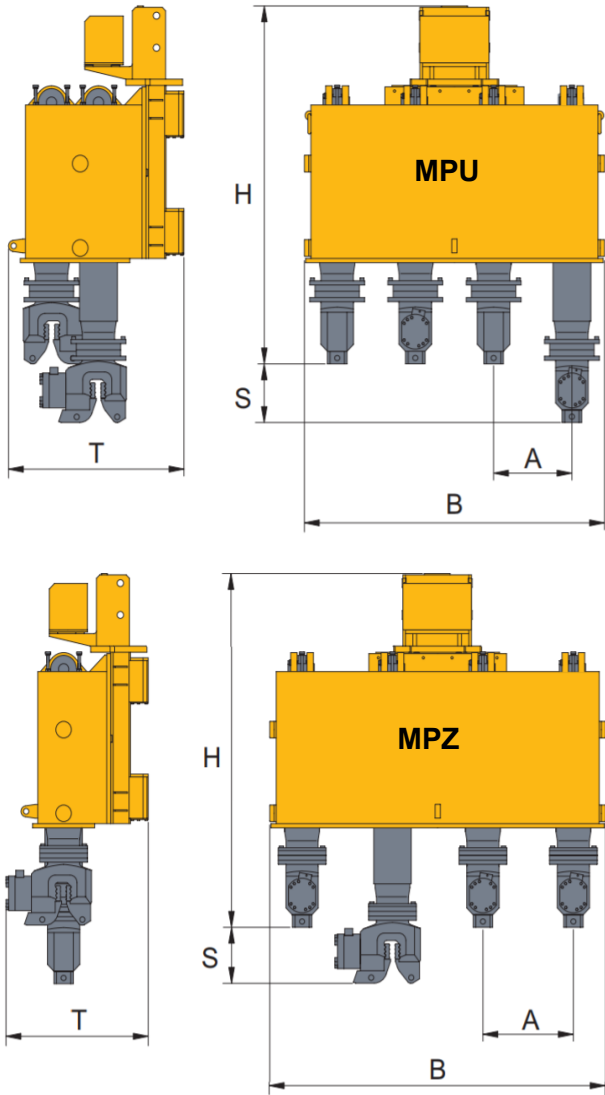

Technical Data	MPU	MPZ-700
Height (H)	2625 mm	2625 mm
Width (B)	2300 mm	2610 mm
Depth (T)	1200 mm	1100 mm
Section Width (A)	600 mm	700 mm
Approx. Total Weight	7900 kg	7000 kg
Transport Weight	8550 kg	7650 kg



Fambo Hydraulic Hammer HR 5000

Technical Data	HR 5000
Length (A)	3600 mm
Length (B)	4800 mm
Driving axis (C)	600 mm
Width (D)	960 mm
Depth (E)	1035 mm
Strokes per minute	0 - 120 rpm
Maximum drop height	0 - 1.2 m
Hammer Weight	7200 kg
Sledge Weight (with ACS & without Transport Frame)	1907 kg
Sledge Weight (with ACS & with Transport Frame)	2290 kg
Universal Adapter Weight	825 kg
Pile Cap (for Sheet Piles) Weight	1379 kg

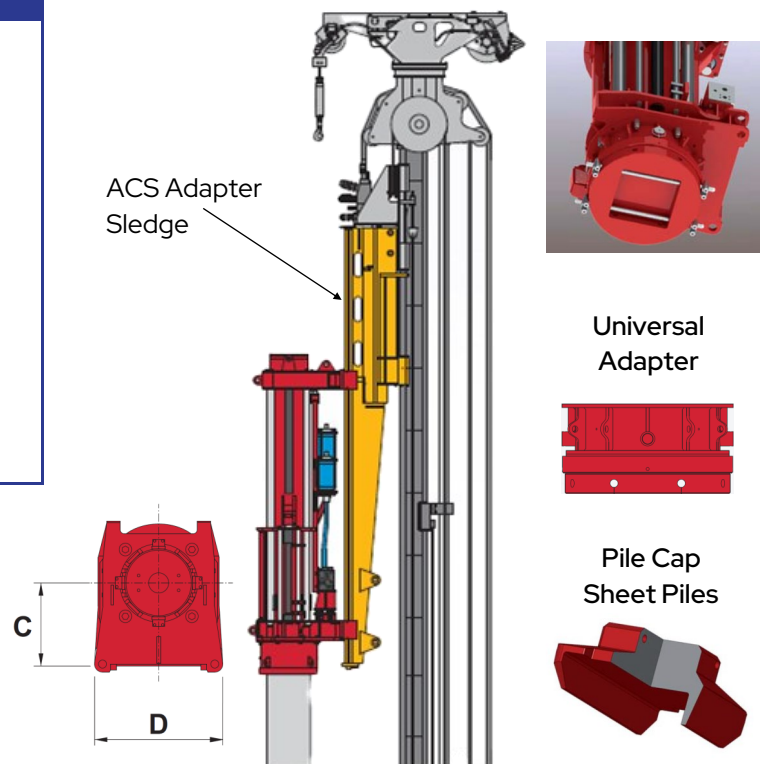
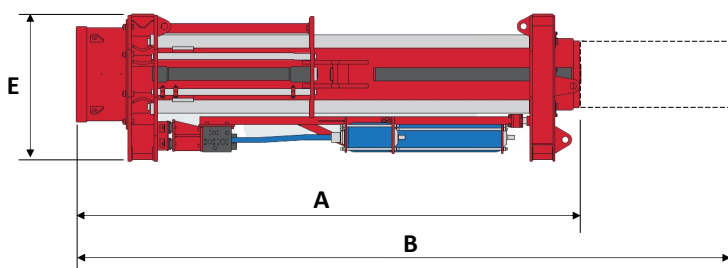

Telescopic Leader Rig RTG RG21T

RTG RG21T in CFA Mode

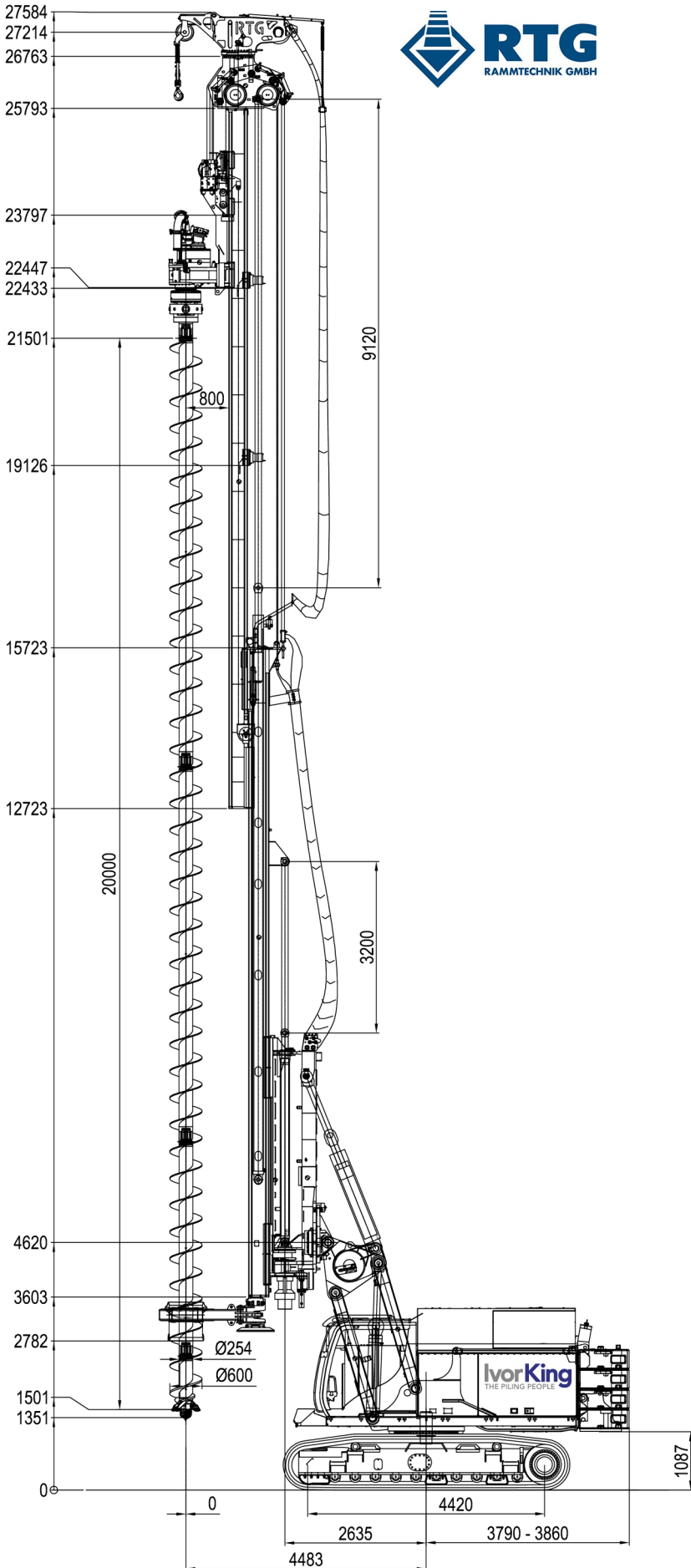

Base Carrier	BS 65 RS
Engine Type	CAT C18
Engine Power	570 kW
Operating Weight (approx.) ¹	85 - 89 tonnes
Transport Weight ²	76 tonnes

²Transport weight = base carrier + leader mast
¹Operating weight = base carrier + mast + attachment

Telescopic Leader Mast	RG 21 T
Total Height	27584 mm
Mast Height Extended	23981 mm
Mast Height Retracted	14861 mm
Maximum Depth	20.0 m
Maximum Diameter	Ø 750mm*
Working Radius Min.	4307 mm
Working Radius Max.	6100 mm
Swing Radius	3860 mm
Extraction Force	260 kN
Crowd Force	140 kN
Torque absorption Max.	150 kNm

* Dependent on length



Telescopic Leader Rig RTG RG21T

RTG RG21T in Double Rotary Mode

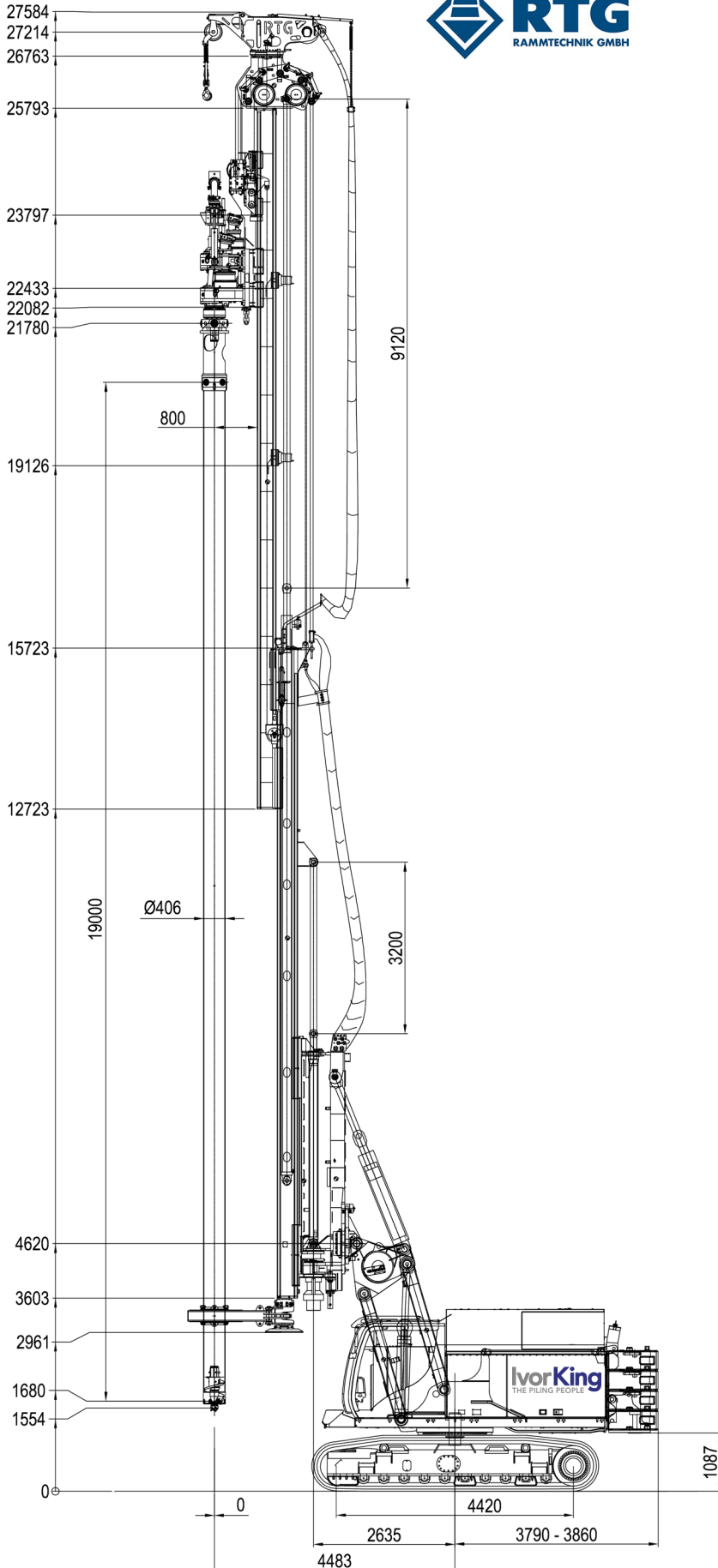

Base Carrier	BS 65 RS
Engine Type	CAT C18
Engine Power	570 kW
Operating Weight (approx.) ¹	85 - 89 tonnes
Transport Weight ²	76 tonnes

² Transport weight = base carrier + leader mast
¹ Operating weight = base carrier + mast + attachment

Telescopic Leader Mast	RG 21 T
Total Height	27584 mm
Mast Height Extended	23981 mm
Mast Height Retracted	14861 mm
Maximum Depth	19.0 m
Maximum Diameter	Ø 610 mm
Working Radius Min.	4307 mm
Working Radius Max.	6100 mm
Swing Radius	3860 mm
Extraction Force	260 kN
Crowd Force	140 kN
Torque absorption Max.	150 kNm



Telescopic Leader Rig RTG RG21T

RTG MB 150-F Rotary Head

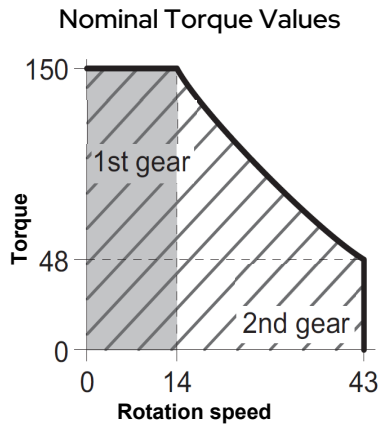
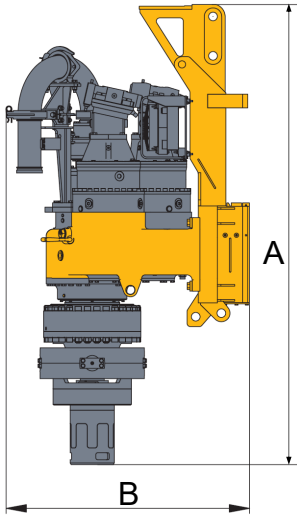

Technical Data		MB 150-F
Height (A)		2690 mm
Width		1260 mm
Depth (B)		1400 mm
Torque Max.	1st Gear	150 kNm @ 14 rpm
	2nd Gear	48 kNm @ 43 rpm
Hydraulic Power Max.		213 kW
Concrete Passageway		125mm
Output Flange (CFA Adapter)		254mm
Total Weight		3900 kg
Transport Weight		4650 kg

RTG DKS 50/100T - Twin Rotary Head



Technical Data		DKS 50/100
Height (A)		3430 mm
Width		1520 mm
Depth (B)		1240 mm
C		260 mm
Casing Torque Max.	1st Gear	80 kNm @ 25 rpm
	2nd Gear	47 kNm @ 39 rpm
Auger Torque Max.	1st Gear	50 kNm @ 41 rpm
	2nd Gear	28 kNm @ 65 rpm
Relative Movement		400 mm
Pulling Force Max.		330 kN
Concrete Passageway		100mm
Output Flange		150mm
Total Weight		5300 kg
Transport Weight		5600 kg

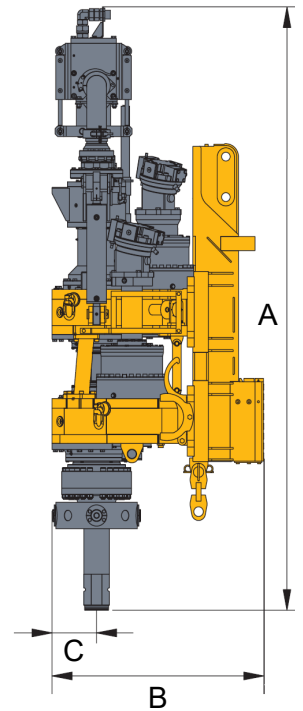

Transportation Dimensions

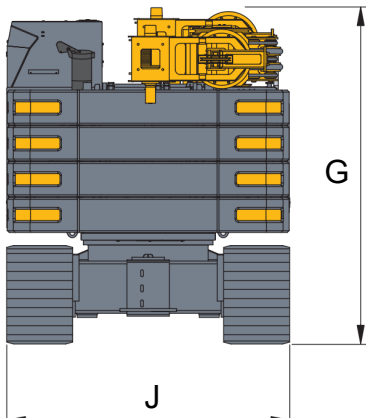

Transportation Dimensions		
Transport length (F) (with aux. winch)		15300 mm
Transport height (G)		3400 mm
Crawler Length (H)		5350 mm
Transport width (J)		3200 mm

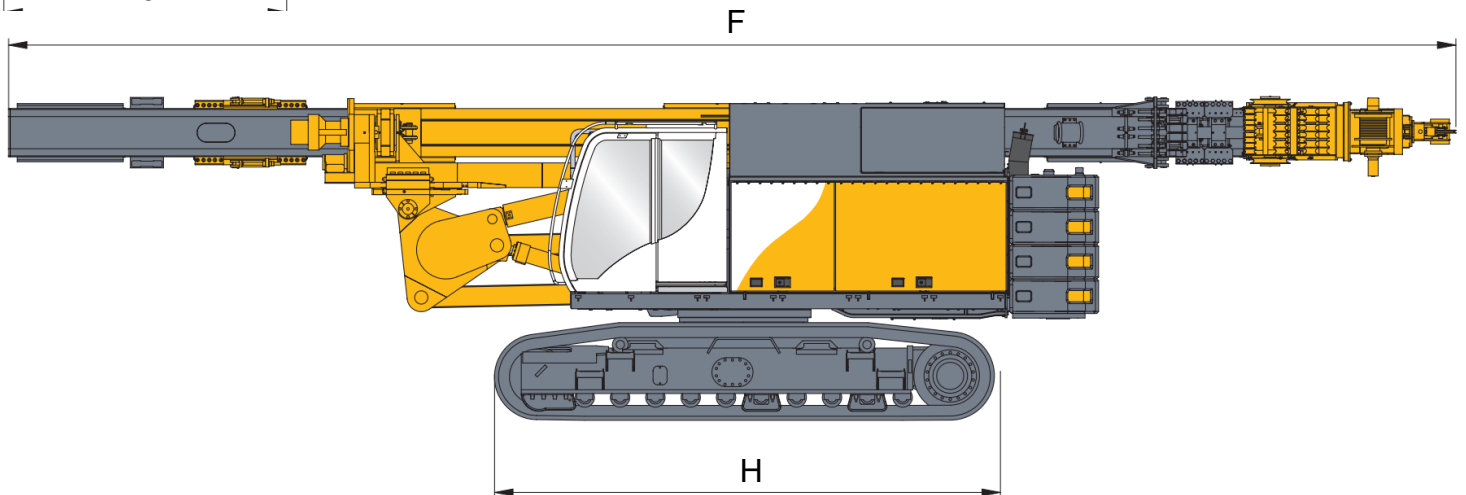

Telescopic Leader Rig RTG RG21T

Additional Rig Data

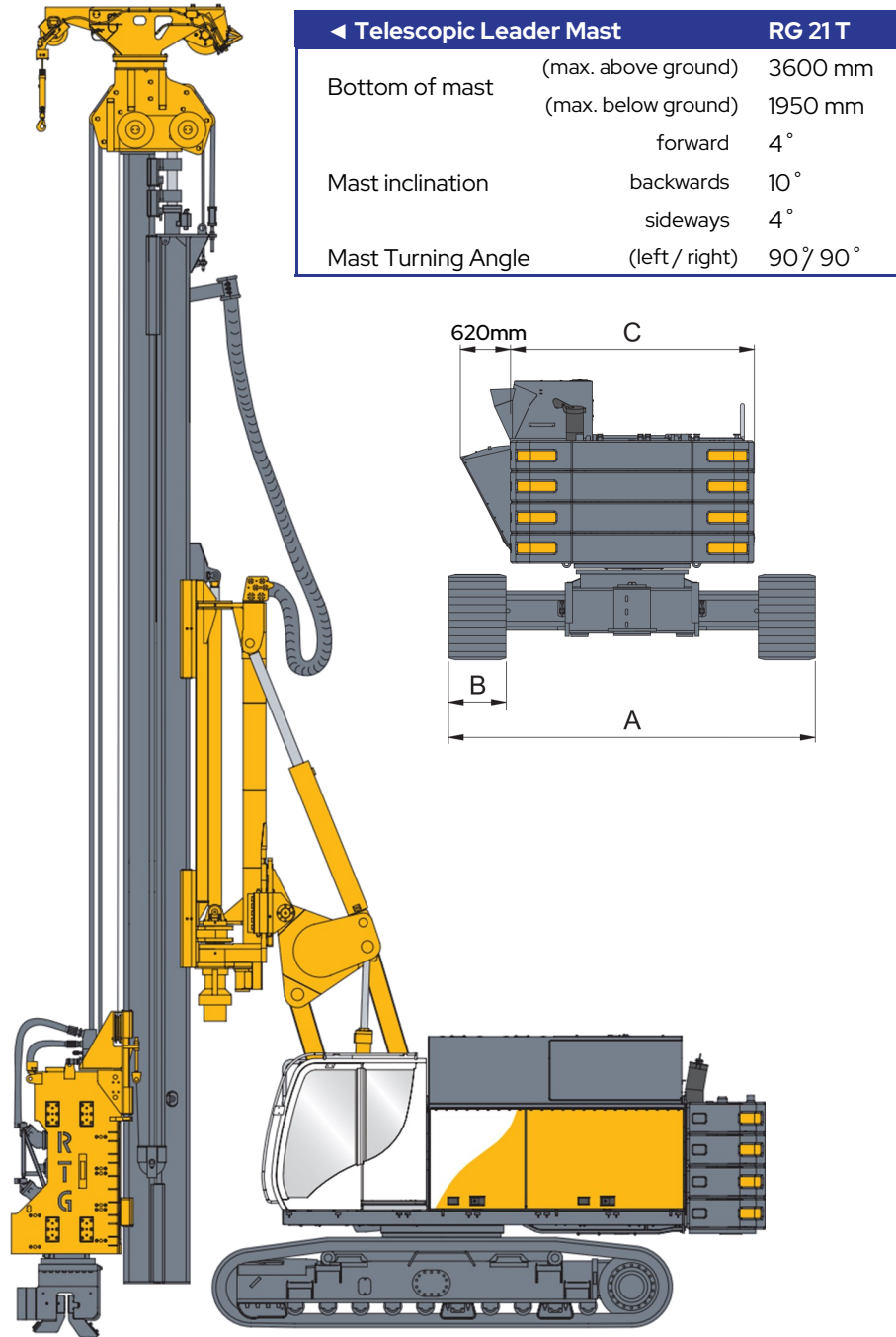

▼ Undercarriage	UW 70 R
Crawler width (A)	3200 - 4700 mm
Track shoe width (B)	900 mm
Upper-carriage width (C)	3000 mm
Wheelbase (D)	4400 mm
Crawler Length (E)	5350 mm

